

Main Office
Golayee Wazirabad
PO Box 208
Kabul, Afghanistan
Phone: +93 202230752
Mobile: +93 700288232
E-mail: dacaar@dacaar.org
Website: www.dacaar.org

REQUEST FOR QUOTATION

Supply and Installation of Complete Solar Water Supply System for

Fatih Abad Village Almar District of Faryab Province

درخواست آفر برای تهیه و نصب واتر پمپ با سیستم انرژی آفتابی

در قریه فاتح آباد ولسوالی آلمار ولایت فاریاب

دفتر مرکزی
گولایی وزیرآباد
پست بکس ۲۰۸
کابل، افغانستان
تلفون: +۹۳۲۰۲۲۳۰۷۵۲
موبایل: +۹۳۲۰۲۲۸۸۲۳۲
دacaar@dacaar.org
وبسایت: www.dacaar.org

DACAAR RFQ 256 PRF-1605/NMFA/2214-NMFA/NFJ1.1/FRY-1805/12.2022

Date: December 01, 2022

DACAAR invites interested parties to submit their sealed offers for Supply & Installation of Complete Set Solar Water Supply System with Fixed Stands and Water Pump for Fatih Abad Village Almar District of Faryab Province as described in Annex (I).

Sealed offers must reach to DACAAR Main Office Logistics Unit located in Street No. 12, Paykobe-Naswar, Qalae-Fathullah, Kabul Province till 4:00pm December 12, 2022.

The bid opening session will be held on December 13, 2022 at 10:00am in DACAAR Main Office in Kabul Province and the bid winner will be notified shortly after the bid opening session.

داکار از کمپنی های علاقمند و واجد شرایط که خواهش اشتراک در پروسه داوطلبی داکار را داشته باشند دعوت به عمل میآورد تا در داوطلبی برای تهیه و نصب سیت مکمل سولر غیر متحرک واتر پمپ زیر آبی مجهز با سیستم انرژی آفتابی در قریه فاتح آباد ولسوالی آلمار ولایت فاریاب اشتراک نمایند که تفصیلات آن در ضمیمه (I) تذکر یافته است.

آفرها باید الی تاریخ 12 دسمبر 2022 ساعت 4:00 عصر به شعبه لوژستیک دفتر مرکزی داکار واقع پایکوب نساوار سرک 12 قلعه فتح الله ولایت کابل سپرده شود.

مجلس آفرگشایی ساعت 10:00 قبل از ظهر تاریخ 13 دسمبر 2022 در دفتر مرکزی داکار در ولایت کابل صورت میگیرد که متعاقباً برنده داوطلبی در اسرع وقت اطلاع خواهد یافت.

Terms and Conditions for the bid winner/participation

1. Delivery and Installation of Solar Water Supply System is in Fatih Abad Village Almar District of Faryab Province as described in Annex (II).
2. Installation & Delivery of Solar pump & solar system should be carried out by the company technicians.
3. DACAAR technical staff at site will inspect the function of solar system water pumps, before delivery and after installation in the targeted area.
4. The bidders have to provide solely information regarding the panels, panels stand and pumps, Also, prepare all the lists of materials needed in this project and attach the design of the solar system to their offer. (e.g. name of manufacturer etc..). Pump daily output design is also needed; otherwise, the offer will not be accepted. However, the materials for this project is herein inlisted in Annex (I), the supplier still can provide their own list required as per their deliberation, as well as to provide desing for connecting the solar panels with main switch and inverter.

شرایط قرارداد برای برنده داوطلبی/ اشتراک کننده گان

1. انتقال و نصب سولر غیر متحرک واتر پمپ زیر آبی مجهز با سیستم انرژی آفتابی در قریه فاتح آباد ولسوالی آلمار ولایت فاریاب که در ضمیمه (II) ذکر گردیده صورت میگیرد.
2. انتقال و نصب سولر پمپ و سولر سیستم باید توسط اشخاص مسلکی شرکت صورت بگیرد.
3. پرسونل داکار نحوه کار سولر سیستم و واتر پمپ را قبل از انتقال و بعد از نصب کردن در ساحه مربوطه نظارت خواهند نمود.
4. داوطلبان مکلف اند تا معلومات (مشخصات) مکمل را در مورد پنل های سولر، انورتر دیجیتال یا مین سویچ عمومی و پمپ زیر آبی که توسط انرژی سولر کار میکند، آب دهی روزانه یا ساعتوار، و کمپنی ساخت پنل ها و پمپ ها را ارائه نمایند همچنان تمام لست مواد مورد ضرورت برای این پروژه لست شده است، ولی باز هم داوطلبان میتوانند که لست مواد مورد ضرورت این پروژه که اضافه ویا کمبود از لست داده شده باشد ضمیمه آفر خویش نمایند، همچنان لین دوانی شیشه های سولر همراهی مین سویچ و انورتر را ترسیم و ضمیمه آفر خود نمایند در غیر آن آفر که معلومات فوق الذکر در آن گنجانیده نشده باشد، داکار از آن صرف نظر خواهد کرد.

5. The contractor must practically show total power (kw) generated by solar panels in proportion to the number of solar panels and submit DACAAR field colleague verified documents to DACAAR Main Office.

5. قراردادگیرنده باید پاور مجموعی سیستم را نظر به تعداد شیشه های سولر عملاً نشان داده و اسناد آنرا که تصدیق انجنیر ساحوی داکار در آن موجود باشد، به دفتر داکار ارائه نماید.
6. Minimum three years' guarrenty of complete system is required after successfully installation of complete solar systems and this fact must be clearly mentioned in the offer.

6. حد اقل معیاد تضمین و خدمات مکمل سیستم بعد از نصب تسلیمدهی مکمل سولر سیستم برای مدت سه سال میباشد، که این موضوع باید بشکل واضح و روشن در اسناد داوطلبی مشخص گردد.
7. 10% of total contract value will be seized as a service/ maintenance guarantee with DACAAR for three years. This amount will be refunded when the service/ maintenance guarantee period is successfully served.

7. 10% از مجموع ارزش قرارداد بطور ضمانت به مدت سه سال نزد داکار محفوظ میماند، و بعد از تکمیل موفقانه دوره ضمانت کار کرده گی سیستم این مبلغ به قرارداد گیرنده قابل پرداخت میباشد.

If, the contractor is not responding during one week for the issue of system maintenance, then DACAAR reserves the rights to use the 10% guarantee to fix the system.

اگر قرارداد گیرنده در طول یک هفته به موضوع ترمیم و نگهداری شبکه پاسخ ندهد، داکار حق استفاده از ضمانت 10 فیصد قید شده را برای ترمیم سیستم محفوظ میدارد.
8. In case of delay without logical reasons in delivery & installation of Solar Systems 0.5% of total cost of undelivered items/ incomplete work will be charged as penalty for each official day of delay.

8. در صورت تأخیر رساندن سیستم ها بدون عذر موجه در وقت معینه آن، مبلغ 0.5 فیصد از ارزش اموال/کار تأخیر شده به طور جرمانه در برابر هر روز رسمی تأخیر از طرف قراردادی تأدیه خواهد گردید.
9. Prices shall be given in Afghani (AFN) and shall include transport plus loading, unloading and complete installation of the systems in targeted areas. Offers without sign and stamp will not accepted.

9. قیمت ها باید به افغانی داده شود و شامل قیمت (مالیه دولتی، انتقال، بارگیری، تخلیه و نصب سولر سیستم باشد). قیمت های بدون مهر و امضا قابل قبول نمیشود.
10. The bid winner must deposit 10% of total contract value as a contract performance guarantee to DACAAR Bank Account, the amount is refundable after successful completion of the contract.

10. شرکت برنده باید مبلغ 10% از مجموع ارزش قرارداد را بحیث تضمین اجرایی مؤفانده قرارداد را به حساب داکار جمع نماید، و مبلغ متذکره بعد از تکمیل مؤفانده قرارداد باز پرداخت میباشد.
11. 2% Tax will be applicable on the companies that has valid business license and 7% Tax will be applicable on the companies that have invalid business license, or on individuals who don't have business license, will be deducted from the contractor as a withholding tax and DACAAR will pay that amount to Ministry of Finance, the amount starts from (1 AFN).

11. 2% مالیه برای شرکت هائیکه دارای جواز با اعتبار میباشد، و 7% مالیه برای شرکت هائیکه دارای جواز معیاد اعتبار آن ختم باشد، و یا اشخاصیکه جواز ندارند توسط داکار وضع گزیده و به وزارت مالیه پرداخت میشود، آغاز مبلغ مالیه از (1 افغانی) میباشد.
12. Payment will be made after successfully & complete installation of solar pump with submission of invoice, confirmation of DACAAR relevant sites accountable within 15 working days.

12. تأدیه پول بعد از تکمیل نمودن مؤفانده قرارداد و بعد از تصدیق نمودن مسؤل ساحوی داکار در جریان 15 روز رسمی قابل اجرا میباشد.

13. Award of the contract will be based on the price, quality, capacity & potentiality of bidder. The evaluation of bidder and their product will be carried out and DACAAR reserves the right to make the decision of awarding contract.
14. DACAAR (Logistics Unit) adheres to National and International laws on child labour, DACAAR makes sure all its suppliers and vendors abide by such laws preventing child labour in all DACAAR activities countrywide.
15. DACAAR has a zero-tolerance policy on sexual exploitation, abuse and harassment, which is defined and described in the policy document "DACAAR policy on preventing and handling sexual exploitation, abuse and harassment".
16. The Humanitarian Organizations (HO) may conduct on- site visit in the contractor's premises (or may take similar measures) to ensure compliance.
13. برنده شدن قرارداد نظر به قیمت، کیفیت، توانایی و ظرفیت داوطلب بوده، و بعد از بررسی کمپنی و اجناس صورت میگیرد. البته داکار حق تصمیم گیری در این زمینه را دارا میباشد.
14. دفتر داکار (شعبه لوژیستیک) با در نظر داشت قوانین ملی و بین المللی برای جلوگیری از کار کودکان مصمم بوده و سعی میکند که تمام فعالیتهای تهیه کننده گان و مشتریان این اداره به این اصل پایند باشند.
15. داکار دارای پالیسی عدم تحمل در مورد سوء استفاده، بد رفتاری و آزار و اذیت جنسی میباشد و موقف داکار در همچون مسایل بطور تفصیلی در پالیسی مذکور تشریح شده است.
16. سازمان های بشر دوستانه (HO) ممکن است تا از محلات و سایت ها به بخاطر اطمینان خاطر و تطبیق درست کار توسط قرار داد گیرنده بازدید بعمل آورده و یا ممکن است اقدامات مشابهی را انجام دهند.

For more details, please visit DACAAR Logistics Unit Main Office Kabul, Sunday through Thursday, from 8:00AM to 03:00PM. Or contact on below Email Addresses:

jamal@dacaar.org or faizullah@dacaar.org

Yours Sincerely,

Manager – Logistics Unit

Date: December 01, 2022



ANNEX (I)

Budget Breakdown / فورم ارانه آفر

DACAAR RFQ 256 PRF-1605/NMFA/2214-NMFA/NFJ1.1/FRY-1805/12.2022

Complete Solar Water Supply System for Fatih Abad Village Almar District of Faryab Province:

S/N	Product Specifications	Unit	Total QTY	Unit Price (AFN)	Total Price (AFN)
1	Submersible Water Pumps, European Made. Static head 195m with water flow 1.6Liter/Sec. A pump to be installed and the second one to be as spare	No	2		
2	Digital Solar Inverter, European Made with water proof metal box and proper lock. The digital Solar Inverter to provide required power from solar panels to the submersible water pump and run the system normally in the year (Jan-Dec)	No	1		
3	Polycrystalline Solar Panels European Made 270 watts. The solar panels will be according to the required submersible pump and inverter powers	No	36		
4	Stand for the Solar Panels to be considered according to attached specifications and drawings	lump sum	1		
5	Submersible Drop power Cable according to pump power design from Inverter to Submersible water pump, according to pump needed power, (made in Turkey or Iranian)	Meter	160		
6	Power Cable 1*6mm ² from Solar panels to Inverter (Made in Turkey or Iranian)	Meter	50		
7	Dry Running sensor inside the well, for protection of submersible water pump with required cable and other needed accessories	lump sum	1		
8	Grounding/earthing (earthing System or Grounding System of network work as a safety measure from lightning arrestor to protect human life as well as equipment and other needed accessories according to attached specifications and drawings)	Set	1		
9	Electrical conduit pipe for external power cables (Made in Taiwan)	Meter	200		
10	Auto fuses AC/DC (Made in Turkey) with other required accessories	lump sum	1		
11	Wire tie white and black	Pocket	2		
12	Water flow meter and needed fittings/ accessories in accordance the pump rising pipe diameter ((Made in Turkish, Iranian or local) best qualities for all)	lump sum	1		
13	Plastic rope (double line) for holding solar submersible water pump diameters (16)mm ϕ with all needed accessories	Meter	151		
14	Delivery pipe (PE 100, PN 16) according to design with required connections, non return valve and fittings from submersible water pump outlet up to water reservoir. The trenches excavation must be (1m deep and 0.7 m wide). PE pipe Lab test is must (supplier will do it in presence of DACAAR QA)	Meter	1,281		
15	Transportation to Village and Installation Charges	lump sum	1		
Grand Total including 2/7% Government Tax, Transportation and Installation Costs: AFN					
Note: The submersible water pump, controller, inverter, solar panel and other important accessories must be European Made. China product is not acceptable.					

Bidder Name: _____ اسم آفر دهنده:

Address & Stamp: _____ آدرس کمپنی و مهر کمپنی:

Mobile No: _____ نمبر موبائیل:

Email Address: _____ آدرس ایمل:

Delivery Time: _____ زمان تحویلدهی:

ANNEX (II)

Information about Types and Guaranty/Warranty of Solar Panel, Solar Pump and Inverter / معلومات و گرنٹی سولر پنل، سولر پمپ و انورٹر

DACAAR RFQ 256 PRF-1605/NMFA/2214-NMFA/NFJ1.1/FRY-1805/12.2022

Complete Solar Water Supply System for Fatih Abad Village Almar District of Faryab Province:

No	Manufacturer of solar Submersible water pumps (Name of Company)	Guaranty period of submersible Water pumps (year)	Name (Model) of Solar Panels (Name of company)	Guaranty period of solar panels (year)	Name (Model) of Digital water proof Inverter (Name of company)	Guaranty period of water proof Inverter (year)
1	Name of company: Model or out let size by inch: Total power by Kw: Made in:		Name of company: Model & out put by Watt: Made in:		Name of company: Model: Total power by Kw: Made in:	

ANNEX (III)
Tentative Work Plan / پلان تخمینی کار
DACAAR RFQ 256 PRF-1605/NMFA/2214-NMFA/NFJ1.1/FRY-1805/12.2022

Complete Solar Water Supply System for Fatih Abad Village Almar District of Faryab Province:

S/No	QTY	Items Description	Location of Installations	Contract Date	Completion Date
I	1 Set	Supply and Installation of Complete Solar Water Supply System	Fatih Abad Village Almar District of Faryab Province	Starts Upon DACAAR Contract Final Approval	January 31, 2023

ANNEX (IV)
Technical Specifications for Submersible Pump and Solar Pump System
DACAAR RFQ 256 PRF-1605/NMFA/2214-NMFA/NFJ1.1/FRY-1805/12.2022

Complete Solar Water Supply System for Fatih Abad Village Almar District of Faryab Province:

S/No	Specification	Unit	Quantity	Remark
1	uPVC Casing pipe Class D installed in the Tube Well	Inch	8.00	Plan
2	Total Depth of Production Well (PW)	M	150.00	Plan
3	Static Water level (SWL) of the Production Well	M	56.00	Plan
4	Well discharge	Lit/Sec	2.50	Plan
5	Water Draw Down of Tube Well	M	40.00	Plan
6	Dynamic Water Level in the Production Well	M	96.00	Plan
7	Submersible Water Pump Installation Depth	M	148.00	Plan
8	Height of Water Tank from the Well surface to top of the water tank	M	68.00	Water tank ground surface location is 52m higher than well surface
9	Length of water delivery Pipe (PE 100-PN16) from submersible water pump to the Water Tank base. With 1% wastage	M	1,281.00	Water tank ground surface is 1120m away from the water well ground surface
10	Length of Electrical Cable from Pump to Inverter with 1% wastage	M	160.00	Solar panel 10m away from water well
11	Average daily safe water is =	Lit/Sec	1.60	during handover to community, the solar system will work for 8h/day
12	Static Head	M	195.00	0.5 bar extra for best water flow inside the RCC Water Tank
13	Total head	M	Static Head + Head losses	Head losses will be calculated by bidder/Supplier, according to delivery PE Pipe needed fittings for calculation of Total head

Some Necessary Specifications:

- 1- For multiple Fixed steel & RCC Stand, the reinforced concrete should be considered M (1:1.5:3). The location of solar fixed stand on the ground is close to water well. The embedded strong hooks J bolt 16mm steel bar is placed in RCC column/ring beams. All steel bars should be deformed 60 grade, and will be used according to the attached drawing of solar panels fixed stand. The European made Solar panels capacity 270 watts is not mandatory, in fact bidder can use other European capacity watts solar panels to run the system normally in the year (Jan-Dec).
- 2- If solar stand is on the ground, 5cm PCC M (1:2:4) is under RCC footings and 5cm gravel/crash on the proper compacted base according to the attached drawings of solar panels fixed stand. If solar panels are on the roof, the RCC ring beam size will be (25*25)cm, 4N12 and stirrup diameter is 10mm on 20cm c/c.
- 3- Bidders should consider the steel angle iron (2x2) inches, the thickness average is 4mm for stands vertically, horizontally and crossing for solar panels frame and steel girder (100x45)mm - the thickness average is 8mm horizontally with proper nut & bolts or proper welding all joints to resist against all type of loads/ pressure, such as heavy Winds, heavy snow, earthquake and etc. according to attached drawings of solar panels fixed stand.
- 4- In addition, two corrosive coating more oil coats should be applied for all angle irons and steel girders of solar panels fixed stand.
- 5- The solar system and solar fixed stand location should be adjusted in accordance to the selected site and the well pumping test result (if needed).
- 6- The bidders should calculate the total head and power losses in pipes, fittings and power cables according to the system requirements along with consideration in their design. Extra charges will not be accepted, but in an exceptional case after Deputy Director/ Head of Program approval, it can be considered, and it depends on the situation. However, any deduction is possible in case of ground reality. Grounding/ earthing (solar system lightening arrestor) of all elements are connected one by one to ground copper rod with copper cable and Aluminum rod or box antenna in accordance to the drawing of solar panels fixed stand. (bidder can physically check the site if they have any questions).
- 7- Solar panels wirings (series & parallel) should be considered in accordance to the power of submersible pump and the inverter/switch by bidder.

Note: The Submersible Water pump, controller/inverter/switch, solar panels and some other important accessories must be European Made. Chinese products are not acceptable.

ANNEX (V)

Drawings & Design / دیزاین

DACAAR RFQ 256 PRF-1605/NMFA/2214-NMFA/NFJ1.1/FRY-1805/12.2022

Complete Solar Water Supply System for Fatih Abad Village Almar District of Faryab Province

Note:

- 1-RCC Concrete Footing and Column M(1:1.5:3).
- 2-J-Anchor Bolt 16mm.
- 3-Deformed Grade 60 steel bar Dia.10mm according to drawing.
- 4-Steel angle iron (2"x2"x4mm).
- 5-Steel girder mini. sizing (10cmx4.5cmx8mm).
- PCC M(1:2:4).
- Foundation Compacted 95%.
- Potable water used.

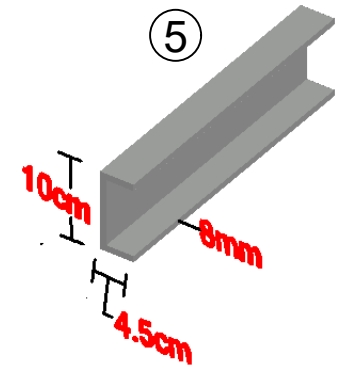
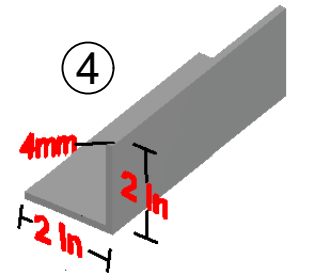
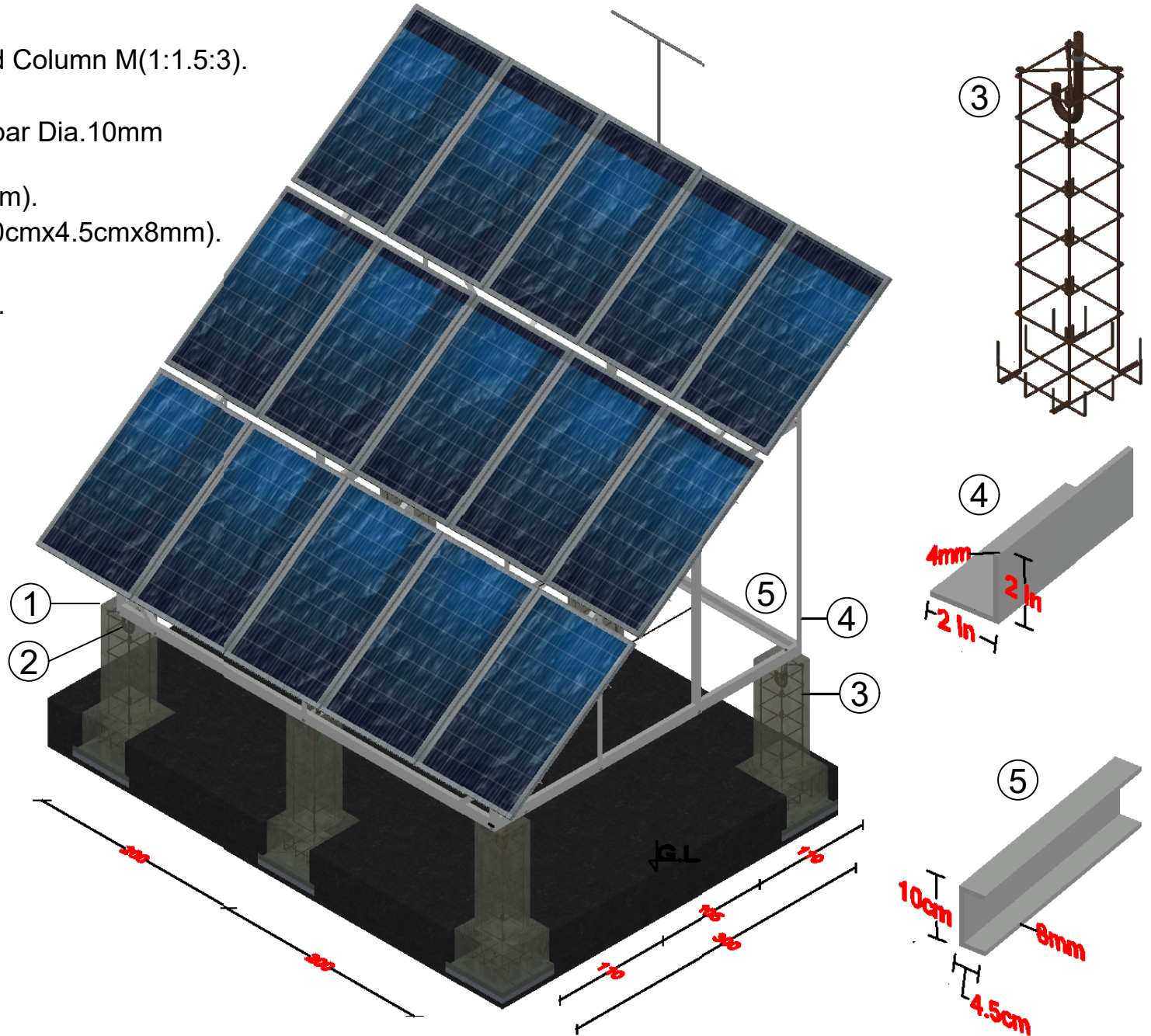
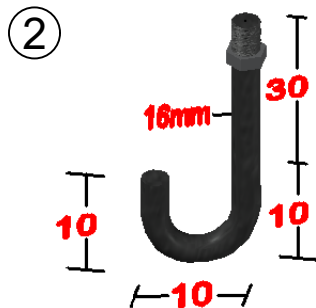
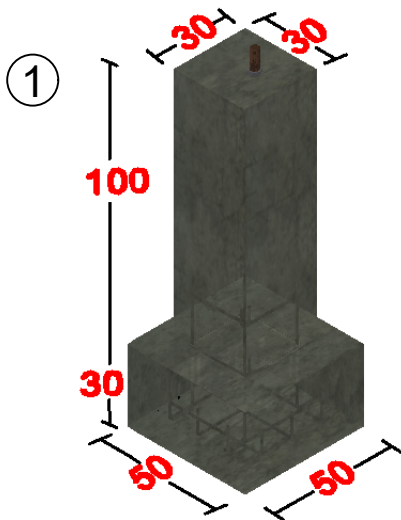

DACAAR / PROGRAMME	Funded By	Any	Village	Any	Drawn & Designed by	Survey/Design Team	Dim. Cm	Sheet Index	Project Title	Solar Design 3D
	Implemented By	DACAAR	District	Any	Reviewed By	Eng.Abdul Malik		1 4	Drawing Title	South East Isometric
			Province	Any	Checked & Approved By	Eng. Abdul Wali Muslih			Date :	Dec.2020

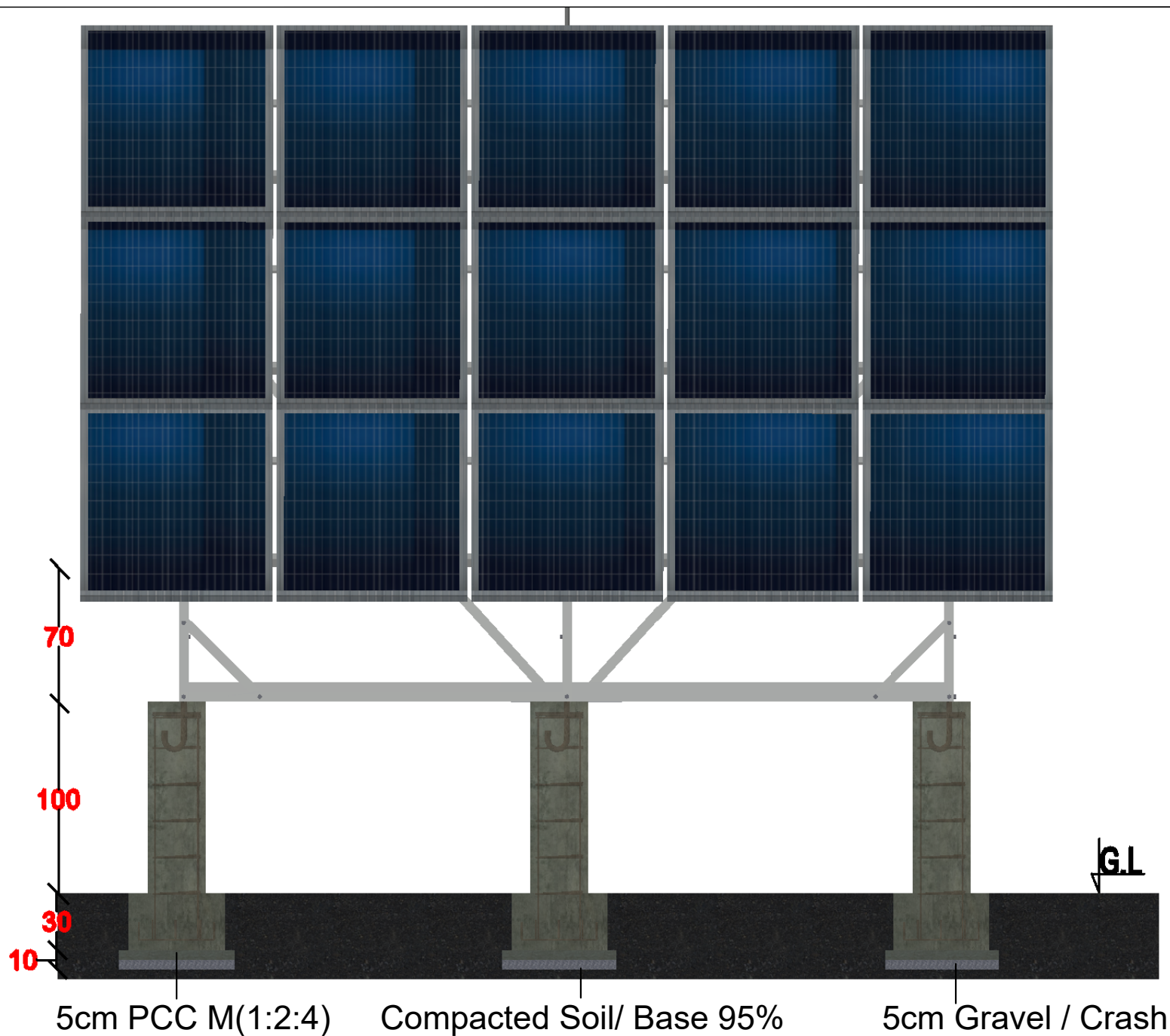

5cm PCC M(1:2:4) Compacted Soil/ Base 95% 5cm Gravel / Crash

DACAAR / PROGRAMME	Funded By	Any	Village	Any	Drawn & Designed by	Survey/Design Team		Sheet Index	Project Title	Solar Design 3D
	Implemented By	DACAAR	District	Any	Reviewed By	Eng. Abdul Malik			Drawing Title	Front View
			Province	Any	Checked & Approved By	Eng. Abdul Wali Muslih		Date :	Dec.2020	

Angle Θ = According to bidder solar system design

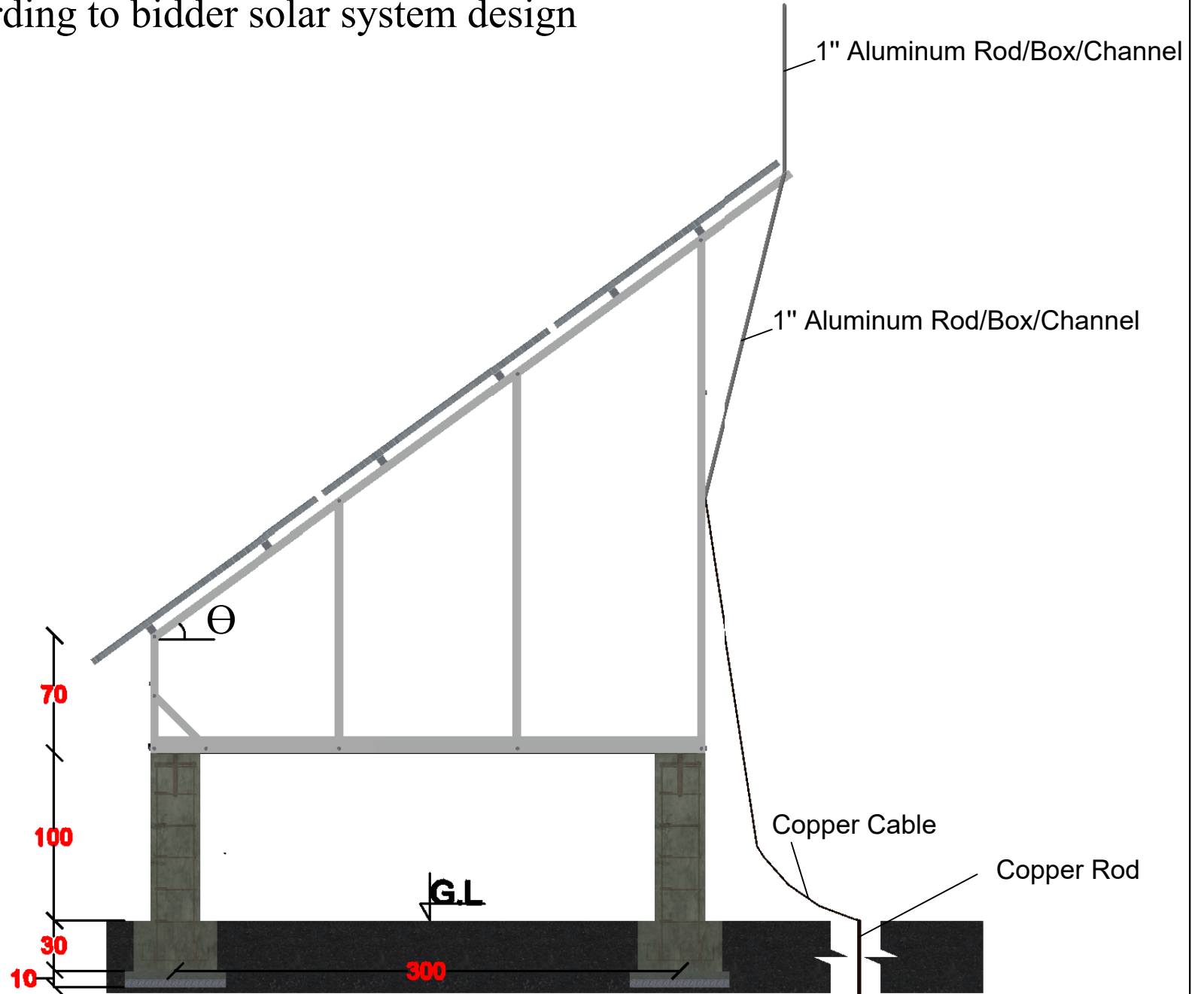

DACAAR / PROGRAMME	Funded By	Any	Village	Any	Drawn & Designed by	Survey/Design Team	Dim. Cm	Sheet Index	Project Title	Solar Design 3D
	Implemented By	DACAAR	District	Any	Reviewed By	Eng. Abdul Malik		3 4	Drawing Title	Right Side View
			Province	Any	Checked & Approved By	Eng. Abdul Wali Muslih			Date :	Dec.2020

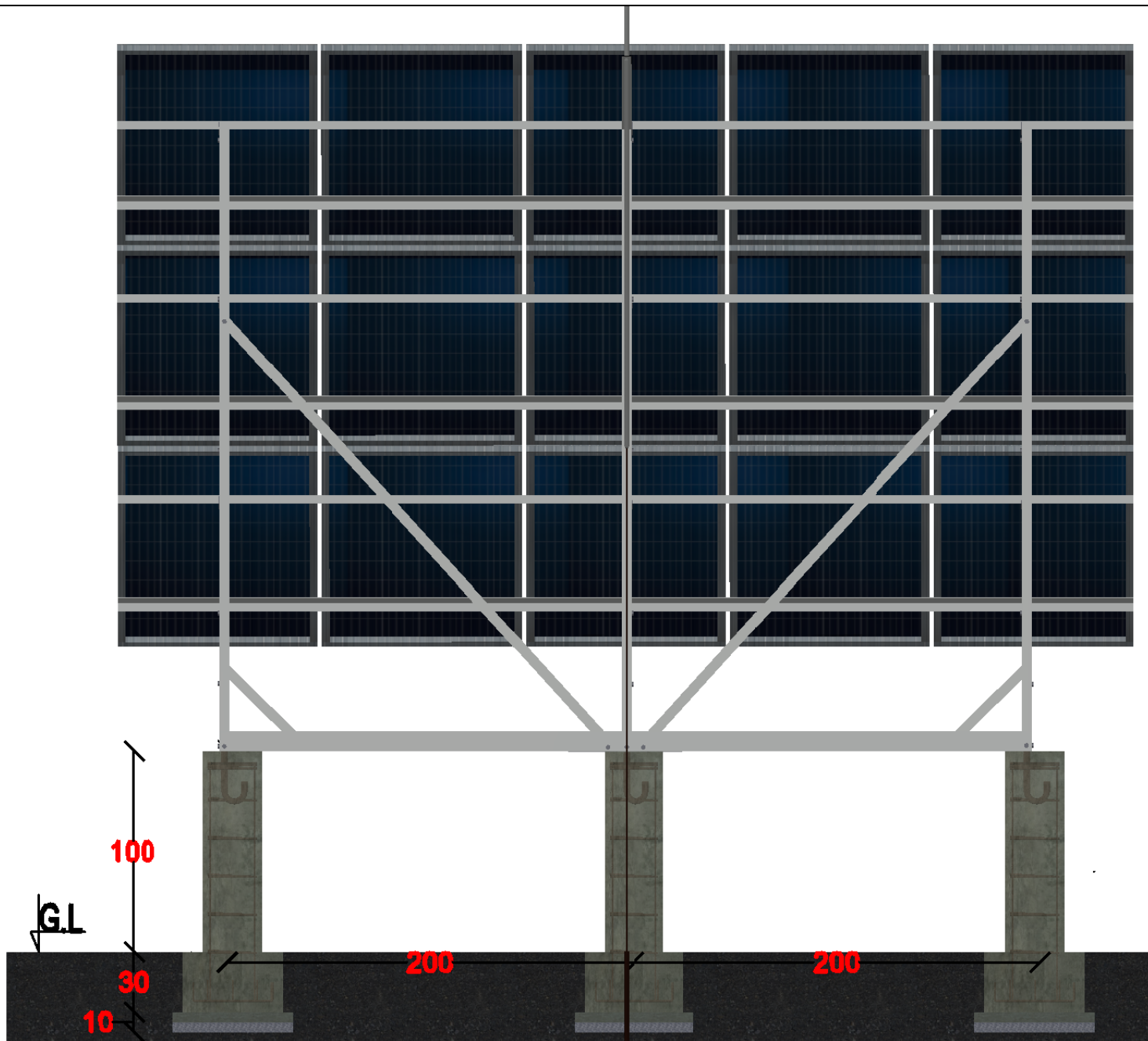

DACAAR / PROGRAMME	Funded By	Any	Village	Any	Drawn & Designed by	Survey/Design Team	Dim. Cm	Sheet Index 4 4	Project Title	Solar Design 3D
	Implemented By	DACAAR	District	Any	Reviewed By	Eng. Abdul Malik			Drawing Title	Back View
			Province	Any	Checked & Approved By	Eng. Abdul Wali Muslih			Date :	Dec.2020